

Smartz USER MANUAL



Copyright Information

Copyright Smartz Operations Pty Ltd. All rights reserved.

The information contained in this User Manual is the sole property of Smartz Operations Pty Ltd and may not be duplicated without permission. This User Manual may be revised or replaced by Smartz Operations Pty Ltd at any time and without notice. Please ensure that you have the latest version of this manual; in case help is required please contact Smartz Operations Pty Ltd Technical Support Department.

Table of Contents

Copyright Information	2
Table of Contents	3
Preface	4
Purpose of this manual	4
Qualification of Personnel	4
Warranty	4
Document Conventions	4
Accessibility of this Manual	4
1.0 Safety Information	6
1.1 Definitions	6
1.2 Warnings	7
1.3 Cautions	11
1.4 Symbols and markings	12
1.5 Label	15
1.6 Patient Privacy and Security	15
2.0 Overview	17
2.1 What is the Smartz® system	17
2.2 Indications for Use	17
2.3 Features	18
2.4 Benefits of the Technology	20
2.5 The Smartz® System Components	21
3.0 User Instructions	26
3.1 Smartz® pod Battery Installation & Replacement	26
3.2 Smartz® sensor Pad/briefs/briefs	27
3.3 Clipping Smartz® pod onto Smartz® sensor Pad/brief	27
3.4 Smartz® pod Indicator Light Colours	30
3.5 Smartz® dashboard	30
3.6 Dashboard Features	33
3.7 Additional Features	36
3.8 Smartz® Notification App	36
3.9 Smartz® pod Cleaning Instructions	38
3.10 Disposal	40
4.0 Troubleshooting, Contact and Support	43
4.1 Troubleshooting	43
4.2 Contact and support	43
5.0 Appendix A Smartz® System Specifications	45
Smartz® Physical Specifications	45
Smartz® Electrical Specifications	45
Smartz® pod Bluetooth Specifications	45
Smartz® Software Specifications	46
Smartz® System Transport and Environmental Specifications	46
Smartz® System Patient Environment	46
6.0 Appendix B: Accessories	53
6.1 Smartz® node	53
7.0 Glossary	55

Preface

Purpose of this manual

This manual contains important information regarding the safe operation of the Smartz® system.

Ensure that the information contained in this manual has been read and understood before operating any component of Smartz® system.

Further help on Smartz® system is available in the Smartz® dashboard.

The word **Patient** is defined as the person being cared for.

This manual forms the Instructions for Use of the Smartz® device.



WARNING

Before operating the Smartz® system read, understand and strictly follow the information contained in Section 1.0 Safety Information.

Qualification of Personnel

Read the Smartz® system warnings and cautions prior to usage. Smartz Operations Pty Ltd recommends that the registration and maintenance of the Smartz® system be performed by personnel with authority to make decisions on behalf of the organization. Only use original parts and equipment approved by Smartz Operations Pty Ltd.

Warranty

Information regarding product warranty will be available from a sales representative or Smartz Operations Pty Ltd.

Document Conventions

This document uses the following typographic conventions:

Screen names and screen displays: **BOLD+Calibri**

Accessibility of this Manual

This IFU can be accessed from the Smartz® dashboard. A hard copy of this IFU can be requested free of charge by contacting Smartz Operations Pty Ltd and may be delivered within up to 14 calendar day

SECTION 1

**SAFETY
INFORMATION**

1.0 Safety Information

1.1 Definitions

This manual uses three indicators to highlight critical information: **WARNING**, **CAUTION** and **Note**. These are defined as follows:

WARNING

A WARNING indicates a condition that can endanger the Patient or the Smartz® system operator.

CAUTION

A CAUTION indicates a condition that can damage the equipment.

Note:

A Note indicates points of particular emphasis that make the operation of the Smartz® system more efficient or convenient.

In order to use the system correctly and efficiently, and to help prevent incidents, please pay attention to Section 1.2 Warnings, Section 1.3 Cautions, as well as all warnings and cautions contained throughout this manual.

1.2 Warnings

General Warnings Related to the Use of Smartz®

WARNING

The Smartz® system must be used according to the instructions provided.

A Patient in a clinical environment is highly vulnerable to the risks of infection. Dirty or contaminated equipment is a potential source of infection. . Follow all internal procedures within your organization, as well as any maintenance procedures, to reduce the risks of infection.

To reduce the risk of infection, organization's standard operating procedures for cleaning, disinfection and hygiene must be followed at all times. At a minimum thorough handwashing should be performed before and after handling any part of the Smartz® system.

Smartz® is not a substitute for standard care practices. Ensure that care personnel are able and prepared to take suitable action should any part of the Smartz® system experience a problem.

If there is a leakage, as there may be with any continence product, there may be a risk of rash, sores and/or compromise of skin integrity requiring medical intervention during a continence assessment. Care personnel should continually monitor and interact with the Patient.

The Smartz® sensor Pad/Brief/diaper should not be applied to a Patient who has a known pre-existing skin condition, such as a rash, sores and/or a compromise of skin integrity; unless the use of a continence containment product with the Patient has been assessed and is in accordance with organization clinical practices.

Some Patients may be sensitive to materials used in the Smartz® components. It is important that the Patient's care provider continually monitors and interacts with the Patient. If the Patient is sensitive to the materials used in the Smartz® components, discontinue use and contact Smartz Operations Pty Ltd.

If a Patient develops a skin irritation as a result of wearing the Smartz® sensor Pad/brief or pod, discontinue use and care personnel should continually monitor and interact with the Patient. The Smartz® sensor Pad/brief and pod should not be worn for prolonged periods of time in one use.

If the ambient temperature is not reported correctly to within ± 2 Degrees Celsius within the immediate vicinity of the pod, please disregard the measurement. Care personnel should continually monitor and interact with the Patient.

Falls are not guaranteed to be detected. This feature is not intended to be a substitute for standard care practices. Care personnel should continually monitor and interact with the Patient.

Smartz® sensor Pad/briefs could potentially pose a biohazard risk. The Smartz® sensor Pad/briefs should be disposed of as per the standard operating procedures, with regard to used continence containment products, of your organization.

The LED Indicator lights on the Smartz® pod indicate different events and functions. Refer to the section 3.4 Smartz® pod Indicator Light Colours for information on the LED Indicator light definition before determining the relevant user action.

Ensure Smartz® system components are stored and transported according to the specifications defined in 5.0 Appendix A Smartz® System Specifications.

Antivirus is recommended for the smart devices using any Smartz® software to reduce the risk of third-party intervention.

Patients may safely use all of the functions of the pod described in this user manual when in use.

No parts of the Smartz® system are intended to be supplied sterile.

For Smartz® to work effectively the Pad/brief must 1) be capable of managing (acquiring and storing) typical void output from the individual when a fresh Pad/brief is applied; if in doubt larger capacity products should initially be used; and 2) the Pad/brief must be applied correctly as per manufacturer instructions as incorrectly fitted Pad/briefs may result in leakage.

General Warnings Related to System Installation

WARNING

The following warnings are related to the use of the device in reasonably foreseeable environmental conditions:

The Smartz® system must not be installed in an environment that limits or prohibits RF transmitting devices.

The Smartz® pod, sensor Pad/brief and app must not be used in the presence of medical imaging equipment such as MRI machines, ECG machines, Defibrillators, etc.

Do not connect items which are not specified as part of the Smartz® system, or compatible with the Smartz® system.

The Smartz® pod and Smartz® sensor Pad/brief must not be stored or placed close to radiant heat sources, such as a lit fireplace or radiant heater.

The Smartz® pod and sensor Pad/brief must not be stored or placed close to the sources of steam, such as steam kettles.

The Smartz® pod and sensor Pad/brief must not be stored or placed close to microwave ovens.

Warnings Regarding Maintenance

WARNING

The Smartz® pod should be inspected for any visible damage during everyday use and not less frequently than every 12 weeks.

Never use any component or accessory of the Smartz® system that appears to be damaged or not functioning correctly. If any signs of damage or malfunction are evident, discontinue use and contact the supplier of the Smartz® system. Examples may include a broken hinge pin, sensor gold teeth, clip mechanism, or battery lid and contacts.

If the cause of the problem with any component or accessory of the Smartz® system cannot be determined, contact your supplier of the Smartz® system. Do not use the Smartz® component that is affected until the problem has been corrected.

Do not attempt to repair, modify or service any component or accessory of the Smartz® system. The system does not contain any user serviceable parts. Doing so might cause damage and/or void warranty.

Only clean Smartz® components with cleaning agents specified in cleaning instructions. Read and follow the cleaning and additional instructions on the cleaning agents to clean the Smartz® components.

The Smartz® sensor Pad/brief is intended for single use only. Use and disposal of the Pad/briefs shall be as per Pad/brief manufacturer instruction.

Only perform upgrades to any software components of the Smartz® system by following instructions provided by the supplier of the Smartz® system.

Never use accessories, detachable parts or materials that are not described in this User Manual. To order new accessories, please contact supplier of the Smartz® system.

The Smartz® pod must not be serviced or maintained when in use on a Patient.

The only servicing of the Smartz® pod required by the operator is to replace the battery – refer to Section 3.1 Smartz® pod Battery Installation & Replacement.

Warnings Regarding Oxygen

WARNING

The Smartz® system is NOT suitable for use in the presence of a FLAMMABLE ANAESTHETIC MIXTURE WITH AIR or with OXYGEN or NITROUS OXIDE.

Warnings Regarding Instructional Safeguards for batteries

WARNING

The Smartz® pod contains a user replaceable coin cell battery, type CR2016, contained behind a snap-fit battery compartment lid that requires a small flat tool to open.

Do not ingest battery as it may result in a Chemical Burn Hazard.

If the coin cell battery is swallowed it can cause severe internal burns in just 2 hours and lead to death.

Keep new and used batteries away from children.

If the battery compartment or the pod housing does not close securely or is damaged, stop using the product and keep it away from children.

If batteries might have been swallowed or placed inside any part of the body, seek immediate medical attention.

Warnings Regarding Home Use

WARNING

If sensors show signs of degradation, functional performance may be affected and device use should be discontinued

Never use any component or accessory of the Smartz[®] system that appears to be damaged or not functioning correctly. If any signs of damage or malfunction are evident, discontinue use and contact the supplier of the Smartz[®] system. Examples may include a broken hinge pin, sensor gold teeth, clip mechanism, or battery lid and contacts.

In the event that pets, pests or children tamper with or affect the device, the performance of the device may be affected and device use should be discontinued. Store the device securely away from pets, pests and children when not in use.

The following warnings are related to the use of the device in reasonably foreseeable environmental conditions:

The Smartz[®] system must not be installed in an environment that limits or prohibits RF transmitting devices.

The Smartz[®] pod, sensor Pad/brief and app must not be used in the presence of medical imaging equipment such as Defibrillators, etc.

Do not connect items which are not specified as part of the Smartz[®] system.

The Smartz[®] pod and Smartz[®] sensor Pad/brief must not be stored or placed close to radiant heat sources, such as a lit fireplace or radiant heater.

The Smartz[®] pod and sensor Pad/brief must not be stored or placed close to the sources of steam, such as steam kettles.

The Smartz[®] pod and sensor Pad/brief must not be stored or placed close to microwave ovens.

1.3 Cautions

General Precautions for Use

CAUTION

The Smartz® pod may be damaged by excessive force being applied during cleaning. The cleaning procedures specified in Smartz® components Cleaning Instructions must be followed to prevent damage.

The components of the Smartz® system may be damaged through the use of harsh cleaning products. The cleaning procedures specified in Smartz® components Cleaning Instructions must be followed to prevent damage.

Precautions should be taken when handling the Smartz® pod. Avoid touching the gold pins.

Precautions regarding Electromagnetic Interference

CAUTION

The Smartz® system requires special precautions for electromagnetic compatibility and should be operated in accordance with the recommendations in this manual.

Note: The use of nearby mobile and portable communications equipment using radio frequencies exceeding the levels set in the IEC 60601-1-2 standard may affect its operation.

The use of any accessory other than those specified may lead to an increase in electromagnetic emissions or a decrease in the equipment protection against electromagnetic emissions.

General Precautions Related to the incorporation into the IT-network







CAUTION





The connection of Smartz® system to an IT network that includes other equipment could result in previously unidentified risks to Patient, operators or third parties. The use of other medical or non-medical devices in the Smartz® IT network is not recommended. The IT administrator should identify, analyse, evaluate and control these risks before connecting the Smartz® system to the network.











Changes to the IT network including but not limited to changes in the IT network configuration, connection of additional items to the IT network, disconnection of items from the IT network, the update of equipment connected to the IT network and upgrade of equipment connected to the IT network, could affect the operation of Smartz®. The IT administrator should assess the risks to the Smartz® system before implementing any of these changes.

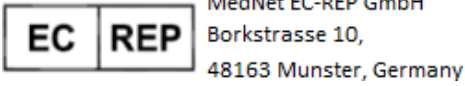

1.4 Symbols and markings

Table 1. Symbols

Symbol	Description
	IEC 15223 -1General Warning sign. This symbol accompanies WARNING in Smartz Operations Pty Ltd product literature.
	IEC 60417-5140 (2003-04) Equipment includes an RF transmitter. This symbol appears on the Smartz® pod.
	IEC 15223-1Serial Number This symbol appears on all Smartz® pod label and package label.
	WEEE (Waste Electrical and Electronic Equipment) This means the product must not be disposed of as household waste. Observe local ordinances for proper disposal. This symbol appears on all Smartz® components. Refer to Section 3.10 Disposal for information and instructions for disposal.
	RCM Compliance with Electrical Equipment Safety System (EESS) of Australian Communications and Media Authority (ACMA) Regulation. This symbol appears on the Package Label.
	CE Marking. Declares that the product conforms to the essential requirements of the applicable EC directives. This symbol appears on the Smartz® pod label and all accompanying documentation and packaging.
	United States FCC FCC ID : SBG-9000POD This Smartz® pod complies with Part 15 of the Federal Communications Commission (FCC) Rules. Operation is subject to the following two conditions: (1) this device may not cause harmful interference, and (2) this device must accept any interference received,

	<p>including interference that may cause undesired operation.</p> <p>This FCC ID appears on the pod Label.</p>
<h1>IP54</h1>	<p>IP rating code of Smartz® pod, which classifies the protection against intrusion from dust and water.</p> <p>This symbol appears on the Smartz® pod.</p> <p>The first digit indicates the level of protection that the enclosure provides against access to hazardous parts. The number 5 indicates that the enclosure is protected from limited dust ingress.</p> <p>The second digit indicates the level of protection that the enclosure provides against harmful ingress of water. The Number 4 on Smartz® pod indicates that pod is protected against water splashed from all directions.</p>
	<p>Keep Dry.</p> <p>This symbol appears on the Smartz® pod packaging.</p>
	<p>Keep Away from direct Sunlight</p> <p>This symbol appears on the shipper carton package.</p>
	<p>Indicates that the packaging should be recycled.</p> <p>This symbol appears on the Smartz® pod packaging.</p>
	<p>Indicates the acceptable temperature range for transport and storage.</p> <p>This symbol appears on the Smartz® pod packaging label.</p> <p>Refer to Section 1.5 Labels.</p>
	<p>Indicates the acceptable humidity range for transport and storage.</p> <p>This symbol appears on the Smartz® pod packaging label.</p> <p>Refer to Section 1.5 Labels.</p>

	<p>Indicates that the device is a Medical Device.</p> <p>This symbol appears on the Smartz® pod Packaging label.</p>
	<p>IEC 15223-1 Device Manufacturer</p> <p>The symbol appears on the Smartz® pod Package Label.</p>
	<p>The date when the Smartz pod was manufactured.</p> <p>The symbol appears on the Smartz® pod Package Label.</p> <p>The date will be adjacent to the symbol in the YYYY-MM format.</p>
	<p>IEC 15223-1 Manufacturers Catalogue Number</p> <p>This symbol appears on the Smartz® pod Packaging Label.</p>
	<p>IEC 15223-1 Indicates electronic instruction for use</p> <p>This symbol appears on the Smartz® pod Package label.</p>
	<p>IEC 60417-5333 Type BF Applied Part</p> <p>This symbol appears on the pod label.</p>
	<p>European Authorized Representative</p> <p>This symbol appears on the Smartz® pod Package label, Shipper carton label and in the user manual.</p>
	<p>Model Number</p> <p>This Symbol appears on the pod label and package labels</p>
	<p>Country of Manufacture</p> <p>This Symbol appears on the Pod package label</p>
	<p>Unique Device Identifier</p> <p>This symbol appears on the Pod package label</p>

	System UDI appears on the dashbaord
	Single Patient Multiple Use This symbol appears on the Pod package label
 <p>TRANSLATED S.R.L. VAT number IT07173521001 R.E.A. 1015467 Registered Office: Via Indonesia 23 - 00144 Roma (Italy) Headquarters: Via Nepal 29 - 00144 Roma (Italy)</p>	Translation This Symbol appears in the User manual

1.5 Label

The pod label is as below

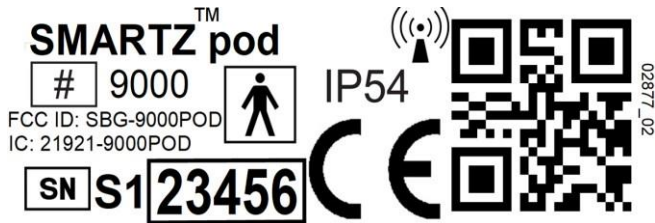

1.6 Patient Privacy and Security

Users are required to accept the EULA (end user licence agreement) and read the privacy policy prior to using the product. All patient data is held on secure Smartz® cloud servers. It is the responsibility of the User to review their Patient’s personal and consent data approximately every 6 months. It is the responsibility of the User to ensure that the physical security of all devices used for Smartz® monitoring is maintained. The privacy policy and EULA can be accessed at: <https://smartzhealth.com/downloads/>

SECTION 2

OVERVIEW

2.0 Overview

2.1 What is the Smartz® system

Smartz® is a safe, smart solution for aged care capable of monitoring a variety of wellness signs in Patients . A Smartz® pod is attached to a Smartz™ sensor Pad/brief(Figure 1). The sensor Pad/brief has embedded sensors which allow for real-time notifications to the caregivers that “it’s time to change”. Smartz® is simple to use, intelligent, affordable, safe and provides peace of mind to caregivers.



Figure 1. Smartz® sensor Pad/brief/diaper and pod

The Smartz® pod is a lightweight, slim, wearable data logger that clips onto a Smartz® sensor Pad/brief. It has been designed for everyday use and comfort for the Patient, including being fully biocompatible. The pod is easy to use and simple for the carer to clip and unclip from a Smartz® sensor Pad/brief.

The Smartz® system is designed to operate continuously to support 24/7 patient monitoring. Data is transmitted safely and securely from the Smartz™ pod to the Smartz™ cloud for processing; health information can be accessed through Smartz® apps, including a central management web app that provides fast, easy to interpret, automatic status updates for all patients using Smartz® and triages those patients needing attention into the “Take Action” section of the screen.

2.2 Indications for Use

The Smartz® system is indicated for use by caregivers or for personal use to collect, transmit and report health information from multiple patients within institutional settings or within a home environment, to provide effective continence care and related conditions.

Contraindications

There are no known contraindications.

Intended Use

The Smartz® system is intended to provide monitoring services of continence management and related wellness data by remote transmission. It is intended for use by caregivers and for personal use to collect, transmit and report health information of users of absorbent hygiene products. The Smartz® System assists in optimizing change of absorbent products and related care routines.

Intended User Population

The operator of the device may be the Carer or the Patient.

2.3 Features

- Continuous patient monitoring
- Dedicated patient data logger (Smartz pod)
- Pod capable of operating continuously for up to 3 months on one battery
- Dedicated wireless data network (Smartz node) to cover larger institutional settings.
- Low cost, easy to use incontinence sensors embedded in standard absorbent articles
- Allow users to enter in additional observations manually
- Software user interface for managing multiple patients, including:
- Goal setting
 - I. Skin Care
 - II. Body position
 - III. Brief fill profile
 - IV. Temperature
 - V. Falls detection
- Alerts
 - I. Time to change
 - II. Skin Care (maximum time in Pad/brief)
 - III. Body repositioning
 - IV. Brief fill profile
 - V. Temperature
 - VI. Falls detection

- Charting
 - I. Voiding Chart
 - II. Pad/brief Fill Profile
 - III. Body Position Chart

- Software includes multi language support, customizable filters for patients and locations, context sensitive help, and useful links.

2.4 Benefits of the Technology

It is important for Carers to take a proactive approach to Patient care. The clinical and productivity benefits of using the Smartz® wearable technology may include:

- Reduced leakage onto clothing and subsequent risk of skin breakdown.
- Reduced risk of Urinary Tract Infections (UTI's) and Incontinence Associated Dermatitis (IAD).
- The Red notifications prompt carers to prioritize care and could prevent the risk of wearers sitting for long periods in wet continence containment products.
- Reduced pressure sore injury due to notification of elapsed time in a particular body position.
- Improved workflow for those caring for Patients; correct use of Smartz® may reduce workload related to:
 - Continence containment products do not need to be checked as the system indicates when to change the product. Carers are reminded to follow appropriate clinical standards of care, and should the Patient suffer from incontinence of the bowel.
 - Reduction in the number of product changes.
 - Reduction in clothing and bed linen changes resulting from less leakage events.
 - Reduction in checking whether Patient requires re-positioning resulting from Smartz® tracking and notifications

The Smartz® system indicates when:

- 'Time to change' has been reached (the volume in the continence containment product has reached a level where a change of incontinence product is required);
- 'Time in product' has been reached (should the incontinence product reach a maximum preferred time with insufficient volume to otherwise trigger a change);
- The Resident's position and length of time in that position and if they require a position change based on the Care Plan.
- Temperature goal is activated when the pod temperature is not within the set temperature range.

This wearable technology may reduce the continence product absorbency required, a reduction in product changes by changing the product only when really needed thus saving time and improving toileting routines. These benefits may result in lower overall costs, fewer hospital admissions, less waste, and more significantly, better individualised care. Patients in Aged Care have a high risk of Pressure Injury, especially those who have limited mobility and are incontinent.

The information Smartz® delivers can be integrated into continence care plans created by Carers and will more accurately meet the true needs of each individual Patient.

2.5 The Smartz® System Components

Smartz® uses industry standard Bluetooth technology to connect to smart devices. Smartz® information can be shared to distribute workload and improve continuity of care.

Smartz® consists of several components to enable the system to function. These components are described in the following table:

Table 2. System Components

Component	Description	User interaction
Smartz® pod	<p>A portable, reusable data transceiver that is connected to the Smartz® sensor Pad/brief and worn continuously or as needed by the Patient.</p> <p>The Smartz® pod is a small and lightweight data logging device. The pod has been designed to an IP54 rating, allowing it to be cleaned by wiping with cleaning solutions. The Smartz® pod contains a CR2016 Lithium battery and an electronic circuit board.</p> <p>Smartz® pods must be linked to a Patient prior to use. The Smartz® pod must be registered to the system by following the instructions provided on the Smartz® dashboard.</p> 	Carer, Patient

Figure 2. Smartz® pod

Smartz® dashboard

Smartz® dashboard: A web app that allows monitoring and managing of patients on any smart device, providing guidance for Carers to deliver holistic care and to utilize Smartz in an optimal manner.

Carer

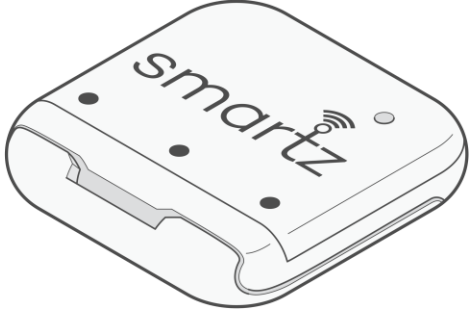
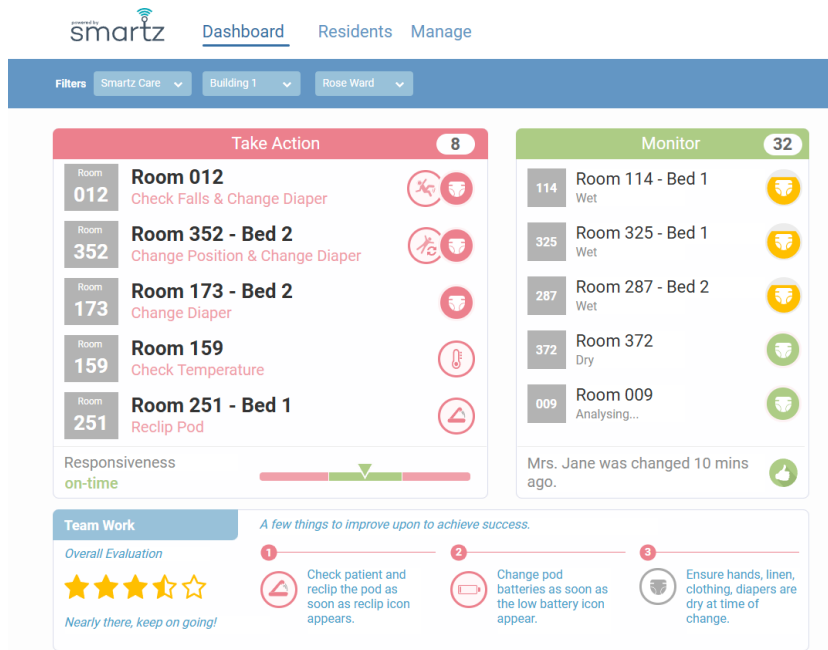

Figure 3. Smartz® dashboard

Smartz® Notification app: The Smartz® Notification app is a mobile extension, allowing users with User accounts to subscribe to notification events for each Patient. This app is available from the Apple store and Google Play store as 'Smartz® Notification'. Push Notification app icon as below:

Carer



Smartz®
Notifica

tion
App

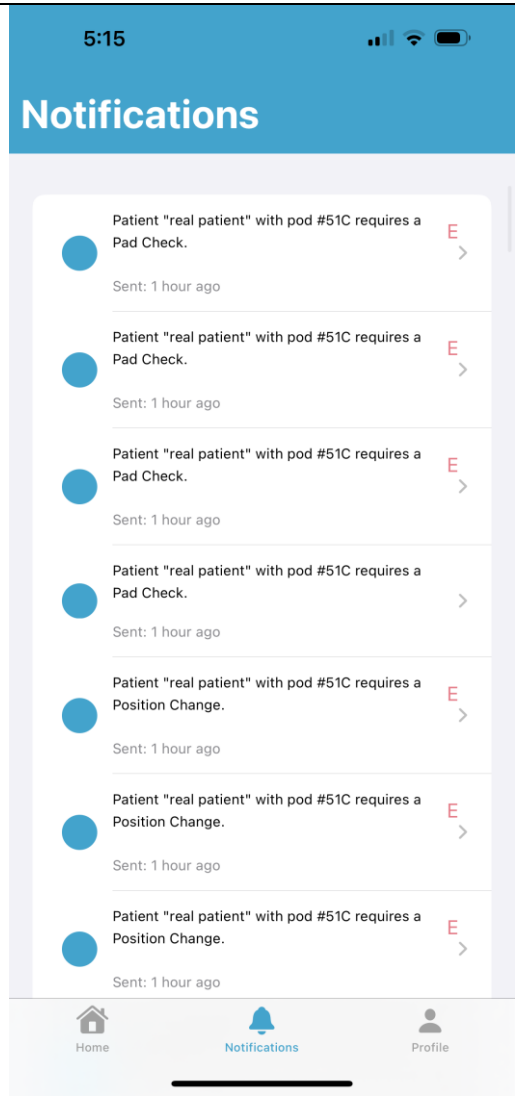

Carer

Figure 4. Notification app

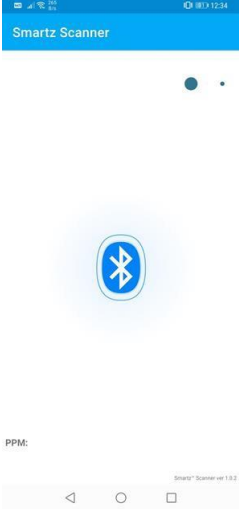
	<p>Smartz® Scanner app: A mobile app running in the background of the user's phone. It receives Smartz® pod data and relays it via the internet to the Smartz® Cloud. The app facilitates a cloud connection whilst roaming outside of the normal network. The app requires mobile data to be active on the device.</p>  <p style="text-align: center;">Figure 5. Scanner app</p>	Carer, Patient
--	---	----------------

Compatible component for the Smartz® System

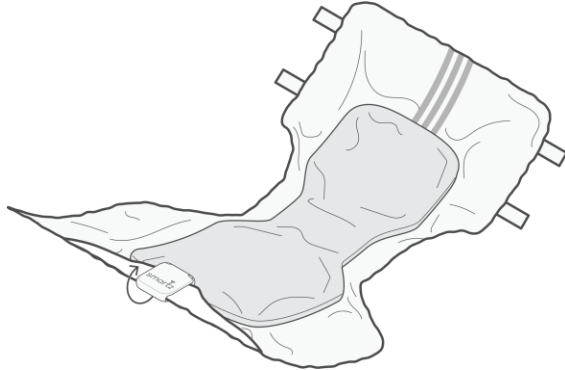
Smartz® sensor Pad/brief/diaper	<p>Disposable Single-Patient-use continence product (brief or diaper), with an integrated wetness Smartz® sensor technology for daily use.</p> <p>The Smartz® sensor Pad/brief is designed to work with the Smartz® system; it consists of a standard continence containment product (brief or diaper) with printed sensors. The sensors detect the accumulation of liquid in the continence containment product over time.</p>  <p style="text-align: center;">Figure 6. Smartz® sensor Pad/brief</p>	Carer, Patient
---------------------------------	---	----------------

Accessory to the Smartz® system (refer to Appendix B for instruction for use of these accessories)

<p>Smartz® node*</p>	<p>An IT router accessory. The node extends the range of Bluetooth signal coverage and relays Smartz® data via Wi-Fi to the Smartz® cloud. A mesh network consisting of multiple Smartz® nodes can be deployed to extend Patient coverage, particularly useful in institutional settings.</p> <div data-bbox="491 348 983 672" data-label="Image"> </div> <p data-bbox="660 772 807 800">Figure 7. Node</p>	<p>IT staff during setup</p>
----------------------	---	------------------------------

***Note:** Smartz® sensor Pad/briefs are not manufactured by Smartz Operations Pty Ltd. Smartz® sensor Pad/briefs contain licensed Smartz® technology and are designed to operate with the Smartz® system.

SECTION 3

USER

INSTRUCTIONS

3.0 User Instructions

3.1 Smartz® pod Battery Installation & Replacement

The Smartz® pod uses a replaceable Panasonic CR2016 battery. Follow the instructions below to install the battery for first time use or to replace the battery:

1. Place the Smartz® pod face up on a flat surface.
2. Insert a flat tool into battery compartment and carefully pry the battery compartment open.
3. Remove the old battery and install the new one (CR2016) with the plus (+) symbol facing up.

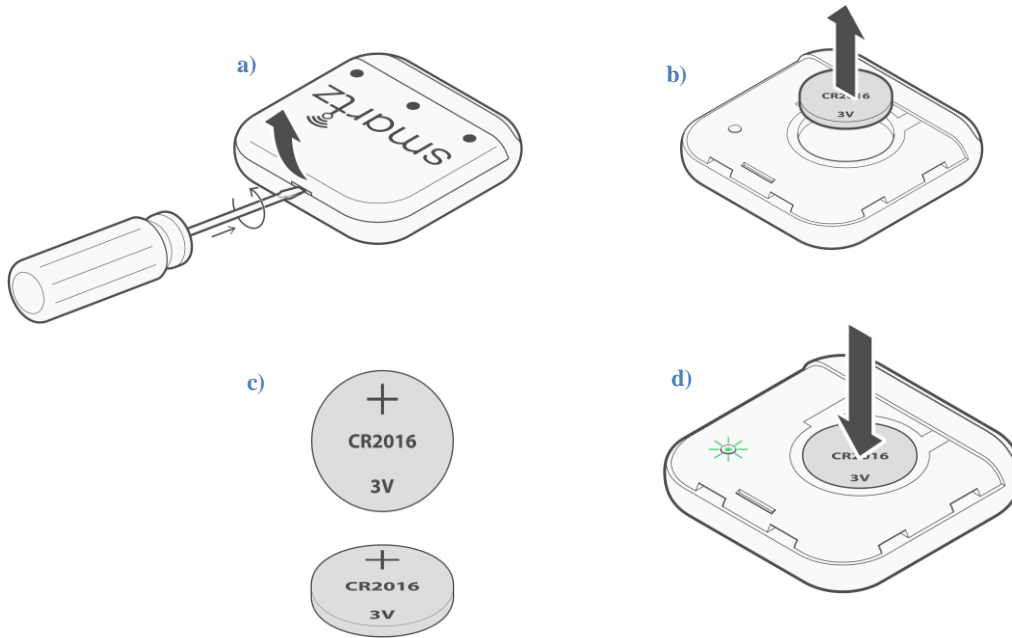

Figure 8. Battery Replacement

4. The light on the Smartz® pod will flash green momentarily to indicate that battery has been installed correctly. For all other pod LED light instructions, refer to Section 3.4 Smartz® pod Indicator Light
5. Gently slide the battery compartment closed until it clicks shut.

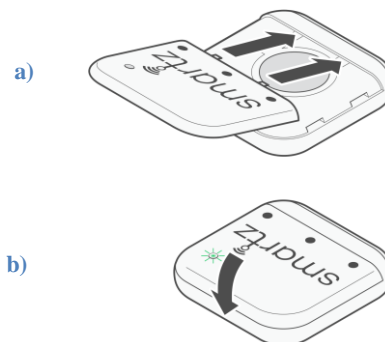

Figure 9. Battery lid

3.2 Smartz® sensor Pad/briefs

The Smartz® system, consisting of the Smartz® pod and Smartz® software, is intended to be used with licensed Smartz® sensor technology applied to compatible incontinence Pad/briefs. Smartz® will not function without a compatible and validated Smartz® sensor Pad/brief. The Smartz® sensor Pad/briefs are supplied from your Pad/brief manufacturer or distributor; Smartz® sensor Pad/briefs are not manufactured or supplied by Smartz®. Compatible Smartz® Pad/briefs for use with this Smartz® system can be identified by locating the Smartz® logo on your Pad/brief manufacturer's package labelling:



Each Smartz® sensor Pad/brief manufacturer has a unique 4-6 digit alphanumeric code supplied by your Pad/brief manufacturer/distributor. The unique code is entered into the Smartz® dashboard during setup. The code will unlock all compatible Pad/briefs supplied by the Smartz® sensor Pad/brief manufacturer; each type of Pad/brief is identifiable through the Pad/brief description within your Smartz® system.

3.3 Clipping Smartz® pod onto Smartz® sensor Pad/brief/diaper

The Smartz® pod must be clipped onto the Patient's Smartz® sensor Pad/brief as follows:

1. Open the Smartz® pod
 - a. If new, take note of the pod serial number on the inside of the lid
2. Align the 3 gold pins of the pod to 3 lines of a **new** brief and close the pod



3. Clip the Smartz® pod onto the front of the Smartz® sensor Pad/brief ensuring that the (3) dots connect with the 3 stripes
4. The light on the Smartz® pod flashes green quickly thrice to indicate that it has been clipped onto the Smartz® sensor Pad/brief correctly. (For all pod LED light instructions, refer to Section 3.4 below)

If the light does not flash green, then unclip and realign and re-clip the Smartz® pod

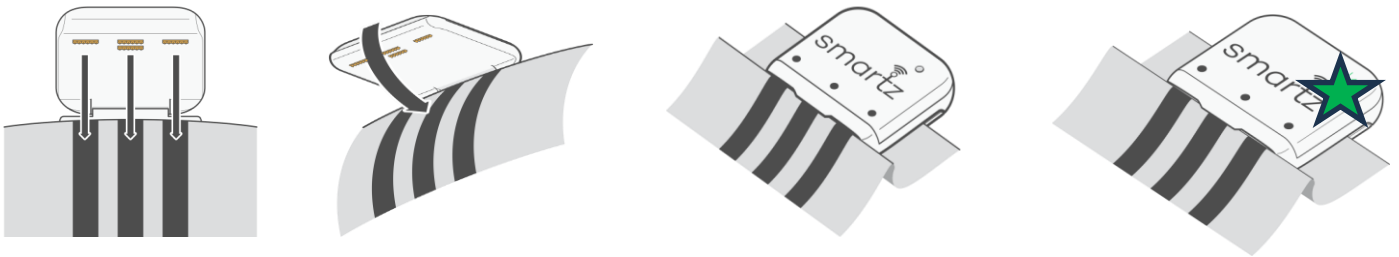

5. Flip the Smartz® pod inwards ONCE only towards the body and tuck in securely. The positioning response relies on the correct and secure position relative to the body.

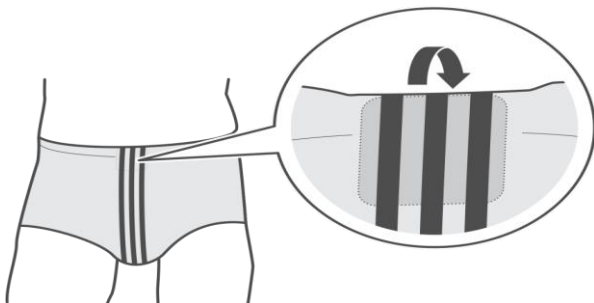

Figure 12. Flip pod inwards towards body once and tuck in securely

3.4 Smartz® pod Indicator Light Colours

The following table is a summary of instructions for the different Smartz® pod LED indicator lights mentioned previously in this instructions document.

Table 3. Pod Indicator Light Colours

Pod State	Indicator Light	Notification to user
Battery inserted	One green flash	Battery OK
Smartz® pod has been correctly clipped onto Pad/brief/diaper	Three green flashes	Smartz® sensor Pad/brief/diaper connected correctly
Default state	Off	No action required
Low Battery	Red flashes	Replace Battery
Dead Battery	Off <i>(when connecting pod to Pad/brief)</i>	Replace Battery or replace Smartz® pod

3.5 Smartz® dashboard

The Smartz® dashboard

- Is a web app that can be used to manage and monitor the wellness features of the Patient.
- Can be accessed on any device (such as a desktop, laptop, or mobile devices) with a secure login via: <http://dashboard.smartzhealth.com/>
- Includes full organization, user, device, patient, and data security and privacy management capability.
- Can be modified to suit regional settings for language and date format.
- Detailed training on the use of the Smartz system including the dashboard is available by contacting your Smartz customer support
- Self-organises all selected Patients into two distinct columns: on the left-hand side are those Patients requiring action ('Take Action' section), and on the right-hand side are Patients connected to Smartz® but not requiring immediate action ('Monitor' section).

Follow the instructions on the Smartz® dashboard to navigate the site and its various functions. For more information on each tab, select the help icon in the top right.

Note: For troubleshooting the dashboard login via: <https://smartzhealth.com/faqs>

System Unique Device Identifier

The unique device identifier details for the System (i.e Smartz System including compatible diaper) are available on the dashboard instead of the product label.

Please refer to the dashboard for the UDI information relevant to the System. The UDI can be seen on the Individual Patient Dashboard.

3.6 Smartz® dashboard features and icons

Daily care Dashboard: Action Resident ASAP

To reduce workload and improve Patient care, Carers should act on the Take Action icons on the left side of the dashboard with high priority.

Left = Take Action ASAP

Right = monitor or no action







The screenshot displays the Smartz dashboard interface. At the top, there is a navigation bar with the Smartz logo and tabs for 'Dashboard', 'Residents', and 'Manage'. Below this is a filter bar with 'Filters' and dropdown menus for 'Smartz Care', 'Building 1', and 'Rose Ward'. The main content area is divided into two columns: 'Take Action' (8 items) and 'Monitor' (32 items). The 'Take Action' column lists rooms with specific tasks and icons: Room 012 (Check Falls & Change Diaper), Room 352 (Change Position & Change Diaper), Room 173 (Change Diaper), Room 159 (Check Temperature), and Room 251 (Reclip Pod). The 'Monitor' column lists rooms with status and icons: Room 114 - Bed 1 (Wet), Room 325 - Bed 1 (Wet), Room 287 - Bed 2 (Wet), Room 372 (Dry), and Room 009 (Analysing...). Below these columns is a 'Responsiveness' gauge showing 'on-time' status. At the bottom, a 'Team Work' panel features a star rating of 4.5 and three numbered action items: 1. Check patient and reclip the pod as soon as reclip icon appears. 2. Change pod batteries as soon as the low battery icon appear. 3. Ensure hands, linen, clothing, diapers are dry at time of change.

Bottom Section - Suggestions for care team to get the most out of Smartz

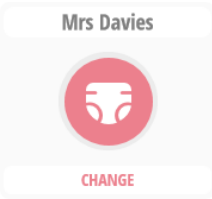
The Responsiveness gauge shows the care team's overall time response to actions shown on the dashboard. As a guide, the indicator should be in the Green Zone for delivering optimal level of care.

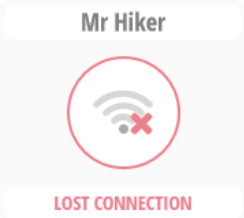

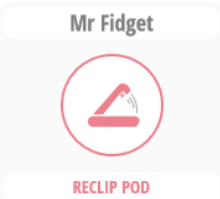

The Teamwork panel provides guidance to the care team on how they can optimally use Smartz to further save time and effort. The Star Rating indicates how well the care team is using the Smartz system.

Icons:

Red Icons: Action required	Description
 <p>Mrs Davies</p> <p>CHANGE</p>	<p>Change Pad/brief Icon: The time to change notification appears when:</p> <ul style="list-style-type: none"> • the time spent in a pad exceeds safe time period (greater than 12 hours) • The pad/brief has reached capacity for the position of the resident and there is risk of leakage • Time exceeds the individual's forecasted pad/brief cycle time • Time exceeds the set goal time limit
	<p>Attend Fall</p> <p>Indicates a potential fall when the fall goal has been switched on and a fall has occurred. Attend the fall.</p>
 <p>Mr Hiker</p> <p>LOST CONNECTION</p>	<p>Lost Connection</p> <p>The Smartz® pod is outside the coverage area and the Bluetooth connection has been lost. Check the pod.</p>
 <p>Mrs Dawson</p> <p>CHECK TEMPERATURE</p>	<p>Check Temperature</p> <p>The surrounding pod temperature goal has gone outside of the set range. Check temperature.</p>
 <p>Mr Fidget</p> <p>RECLIP POD</p>	<p>Reclip Pod</p> <p>The Smartz® pod has been disconnected from the Smartz® sensor Pad/brief. Reclip the pod.</p>
 <p>Mrs Talis</p> <p>REPLACE BATTERY</p>	<p>Replace Battery</p> <p>The Smartz® pod battery is flat. Replace the battery.</p>
 <p>Mrs Albie</p> <p>RE-POSITION</p>	<p>Change Position</p> <p>The Patient has exceeded the set time-in-position goal. Change position.</p>

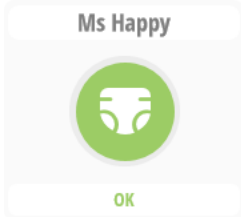
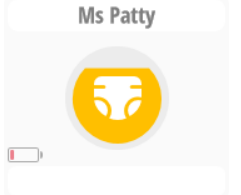
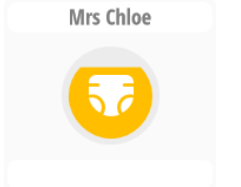
1. Daily Care Dashboard: Other icons

Under the 'Monitor' section, if no Pad/brief has been selected for either the day or night in the system, the dashboard icon indicates 'Pad/brief not selected'. When the pod is first connected to the Pad/brief the 'Analysing Pad/brief' icon will show until the Pad/brief status is recognised

Icon	Description
	<p>Green</p> <p>Smartz® sensor Pad/brief is not yet approaching capacity. No action required.</p>
	<p>Yellow with battery</p> <p>Smartz® Pod battery is running low. Monitor and be prepared to change it.</p>
	<p>Yellow</p> <p>Smartz® sensor Pad/brief is approaching capacity or time to change. Monitor and be prepared to change.</p>
	<p>Product Not Selected</p> <p>No Smartz® sensor Pad/brief has been selected for either day or night period. Select a product if patient is required to wear it for that period.</p>
	<p>Analysing Pad/brief/diaper</p> <p>Shows until status of the Smartz® sensor Pad/brief is recognised.</p>
	<p>Monitor Icon</p> <p>Shows until the Smartz System can find stable readings to generate capacity</p>

2. Smartz Advanced dashboard.

This detailed dashboard contains extra icons that allow for trouble shooting the system.

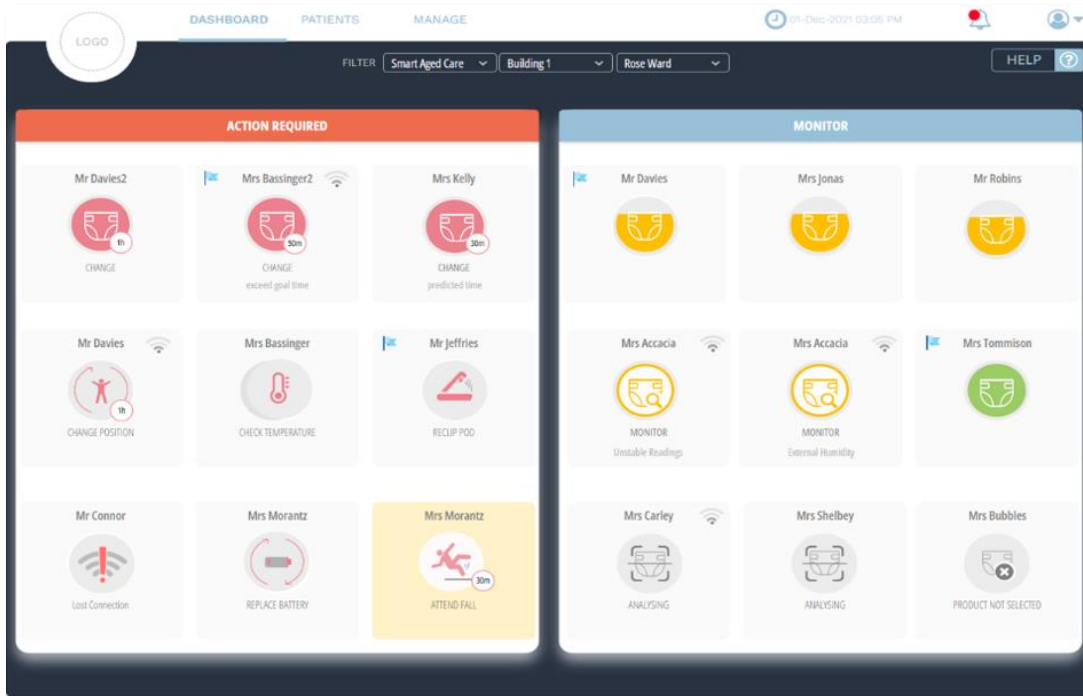

Icon	Description
	<p>Change Icon - Exceed Goal Time</p> <p>Smartz® sensor Pad/brief has exceeded the set time-in-Pad/brief goal. Change product.</p>
	<p>Change Icon - Predicted Time</p> <p>Smartz® system predicted change time. Change product.</p>
	<p>Change Icon</p> <p>The time to change notification appears when the time spent in a pad /brief exceeds safety period (greater than 12 hours)</p>

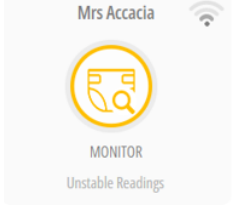
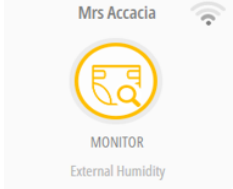
	<p>Safety Alert: Automatically activated when conditions exceed a clinically safe threshold. For example, when a diaper has been worn more than 12 hours</p>
	<p>Waiting for stable sensor readings</p> <p>All status related to Pod not being able to get a reliable sensor reading for volume estimation and alert judgement will be shown as a yellow tile with Pad/brief and clock icon. Includes: Wetness Outside, Core Breakup, and Unstable Sensor Readings.</p>
	<p>External Humidity</p> <p>There is wetness on the outside of the pad/brief due to wet hands or potential leakage</p>

4. Goals and Alerts

Note: refer to section 3.6 to review icons associated with goals

Goals can be set for each Patient using the dashboard 'Goals' tab. Once a goal has been set, a blue flag icon is shown in the advanced dashboard Patient's window on the group / individual dashboard / 'Goals' tab for the selected Patient:

The goals that can be set are:

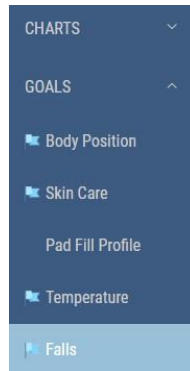

Time in position: Time in position indicates how long the Patient has been in one position, to the nearest minute. The positions recognised are sitting, standing, lying on back, lying on their front and lying on either side. When the user has spent more time continuously in a particular position than the user defined goal, the system generates a Change Position alert. Following this alert could help in alleviating pressure wounds and injuries

Note: Lying on side may trigger an earlier 'Time to Change' than when in other positions due to the fluid pressure on the side cuffs of the Smartz® Pad/brief.

Skin care: ⓘ The system will alert when the user has exceeded the set goal for time in brief (skin care), changing the brief as per the alert could help reduce skin irritations and related skin conditions

Pad fill profile: The system alerts the user when the patient's urine output is lower than the pre-defined goal.

Temperature: The temperature indicates the approximate ambient temperature of the pod surroundings to within +/-2°C. If the Smartz® pod has been correctly folded in toward the abdomen, the temperature indicated will approach the Patient's body temperature and may be used, for example, as an early warning of an abnormal increase in Patient temperature

Note: The Smartz® pod has to be connected to the Smartz® sensor Pad/brief and folded in toward the abdomen. This temperature feature is not intended to measure the physiological temperature of the Patient.

Falls detection: Can be turned on and off. Alerts when the patient's position undergoes sudden changed beyond expected and alerts to check for fall. (see below).

The Smartz® falls detection feature is designed to detect a range of falls from a range of typical heights. While every effort is made to capture every type of fall, some people may fall in a manner outside of this range.

Furthermore, there may be false positive falls events as a result of a specific movement of the device i.e. a falls event reported that is not a true falls event. There may be periodic

network latencies during use outside of the control of the Smartz® product. As a result, a falls notification may not be reported immediately after the event.

Please refer to the warnings and use of the Falls detection feature and do not rely on the Falls detection feature solely. This feature should not replace appropriate standards of care for your Patient.

If a fall has occurred the notification will be displayed as a flashing icon under the 'Action Required/Taken Action' section. By silencing the fall in the 'Individual' page the icon will be removed from the main dashboard.

When setting up a new Patient the falls detection is OFF by default. To activate the falls detection, go to the dashboard, Goals section and follow the instructions. By default, the 'Time in Position' is automatically turned on and set at 2 hours.

If the "fall detected" is ON in the Smartz® Notification app the user will be sent a notification indicating a fall has occurred. To reset the falls, the Pad/brief must be changed and the pod applied to a new dry Smartz® sensor Pad/brief or press the Silence button in the Individual page.

Note: Falls will not be triggered within the first 5 minutes of clipping to a Pad/brief. The Smartz® pod has to be connected to the Smartz® sensor Pad/brief and folded in toward the abdomen.

Setting goals: Statistical measurements are displayed below the goal and on the Individual page showing data from the previous 7 days' history to guide users on how best to set goals for each of their Patients. For more information on each goal, select the help icon in the top right. Goal thresholds being reached may trigger notifications in the Smartz® Notification app if the user has subscribed to them.

Note: The statistical values below the goals and on the Individual page of the dashboard are generally calculated from the previous 7 days of data. Therefore, a continuous set of 7 days of data is required to show meaningful statistical results.

5. Charts

[Voiding Chart](#)

Charts consecutive time periods of patient void activity. Choose the date range you wish to view. The voiding chart displays: 'New Pad/brief', 'Pad/brief removed', 'Pod unclipped', 'Void in Pad/brief', 'Wetness Outside Pad/brief', 'No pod data' and 'Time to Change' which can be deselected. Icons can be filtered by selection. Voids will be displayed when the system calculates stability in the sensor reading, and plots the void based on this reading.

[Pad/brief Fill Profile](#)

The total daily profile shows the total amount of fluid that has gone into the Pad/brief during the 24-hour period. Toggle to see either the day or night profiles separately. The drops indicate the volume output into the Pad/brief. The 'Average' icon indicates volume output over the period of the time selected.





WARNING

- Pad/brief fill profile is only the volume captured in the Pad/brief and does not account for any lost fluid due to toileting, sweat, Pad/brief leakage and other losses
- It is not intended to give a measure of bodily function
- It is only a statistical average of the dates selected compared when there is enough data
- All volume above the estimated leakage point for each Pad/brief is not counted in the calculation for Pad/brief fill profile since the leakage volume may be lost outside of the Pad/brief

[Body Position Chart](#)

The Position Chart visually displays the length of time in each position of a Patient. The position changes and length of time in one position are indicated by coloured time blocks. Light red shows the length of time in one position. Dark red is displayed when a goal has been set and the time in position is exceeded.

Any grey coloured time blocks will mark changes in position e.g. from lying on back to lying on side or rapid movements. Only positions that are stable for at least a few minutes, will be displayed and rounded to the nearest 15 minutes of the hour on the chart. Time windows with no data, such as when the pod is not detected are indicated by a blank time block or by stripes when the pod is unclipped.

LEGEND  stayed in one position  pod unclipped  change in position  no pod data

The exact time length will be shown when hovering over the individual coloured time blocks and will also be listed in a detailed chart when printed.

3.7 Smartz® Notification App

The Smartz® Notification app is a mobile extension, allowing users with User accounts to receive status updates for each Patient. When there are updates on the Care Dashboard, the same updates will be sent to the Smartz Notification app and shown as a Notification on the Smart device. This app is available from the Apple store and Google Play store as 'Smarz® Notification'.

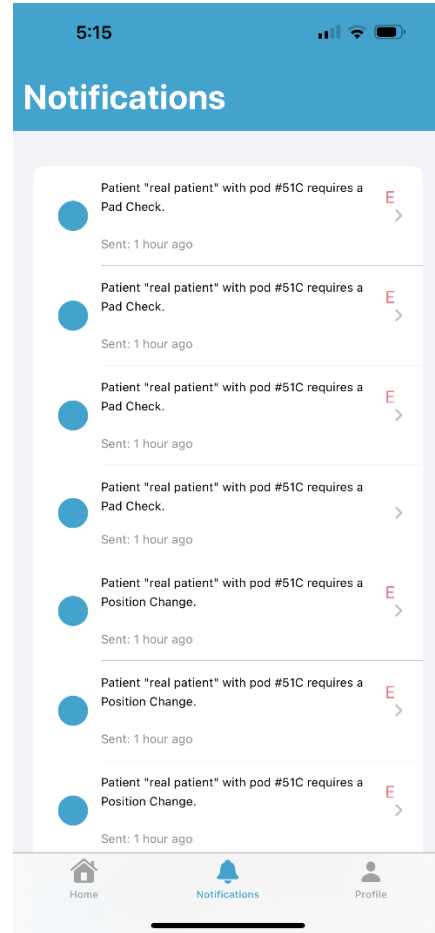
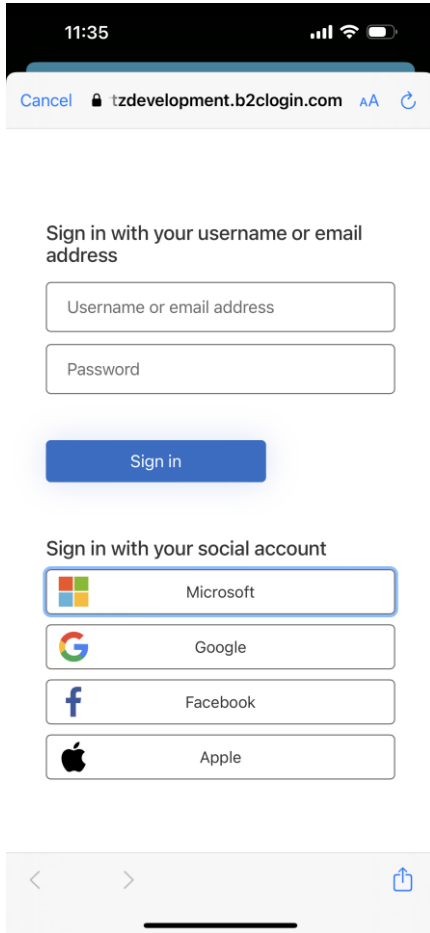

Users will receive remote notifications on the event statuses of their Patients when their device is connected to the Internet. To use this additional feature:

- 1) Ensure the device is connected to the internet
- 2) Obtain the Smartz® Notification app from the app store of the device
- 3) Login using the same User account as that created in the Smartz® app
- 4) Select a Filter corresponding to the group of patients to monitor and receive notifications

Note: Filters can only be configured through the Care Dashboard.

- 5) The system will monitor and send a Notification for the patients belonging to the selected filter. The smart device will show a Notification when it is received.

Note: The smart device needs to be connected to the Internet to receive Notifications.

6) Notifications include:

➤ Brief Change Notification

- This includes notifications related to brief change due to wetness safe/predicted time exceeded

➤ Resident associated notification

- This includes notifications associated with residents position change, temperature exceed, fall event

- Pod associated notification
 - pods unclipped and low battery
- 7) When a Notification has not been actioned upon within a certain time, additional notifications will be sent and appear on the Smart Device.
- 8) Subscription filters:
 - User will need to select the Filter for the group of patients they are caring for as below:

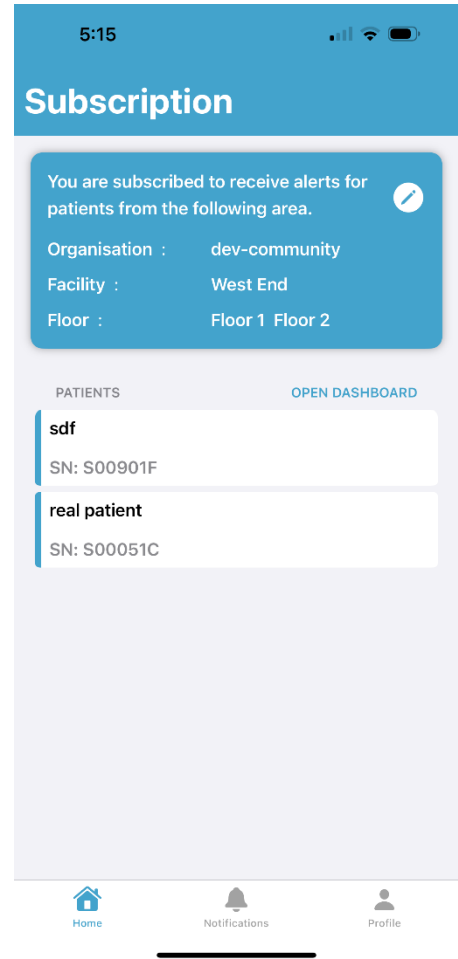
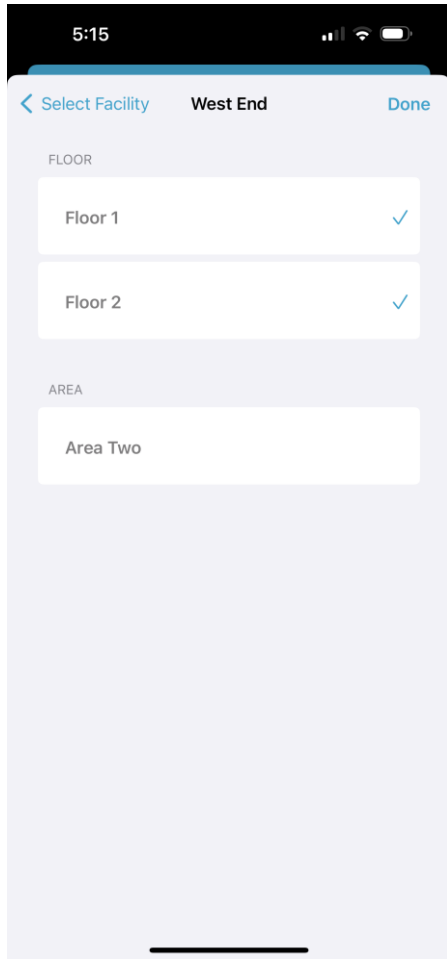

- By default, Notifications will be shown for all Care Dashboard status changes.
- Notifications will only appear for Active Goals.

3.8 Smartz® pod Cleaning Instructions

[Smarz® pod cleaning Guide](#)

Smarz Operations Pty Ltd recognizes that cleaning and disinfection practices vary amongst Home and Care Facilities. It is not possible for Smartz Operations Pty Ltd to be responsible for the effectiveness of cleaning the Smart Pod.

The Smartz® pod is assigned to a resident for the duration of their incontinence management. The pod should be visually inspected regularly, including a quick check of the external surfaces and the area beneath the lid, paying special attention to the four gold serrated teeth. Any signs of contamination, such as urine or fecal matter, should be promptly cleaned according to the guidelines provided below. Additionally, the pod should be disinfected periodically; weekly disinfection is recommended. If the pod is to be reassigned to another resident, it must first undergo disinfection

The Smartz® pod can tolerate up to 1000 cleaning cycles.

[Recommended cleaning solution and precautions](#)

The Smartz Pod is classified as a non-critical item (NHMRC 2010) and can be cleaned with a pH neutral (mild) detergent designed for general-purpose cleaning. In institutional environments, an existing infection control procedure may be followed providing that it does not involve soaking of the Smartz® pod. Detergent-impregnated wipes may be used to clean the Smartz Pod.

CAUTION

- To prevent disease transmission, use disposable waterproof surgical gloves when handling contaminated Smartz® pods.
- Do not soak Smartz Pod in water

Smartz® pod cleaning and Inspection

Clean and inspect the Smartz® pod as follows:

- *The Smartz® pod is IP54 rated for protection from water splashes from all direction, and dust ingress. However, it is not waterproof.*
- *Clean the Smartz® pod by wiping it with cleaning solutions according to the above recommended cleaning Solutions.*

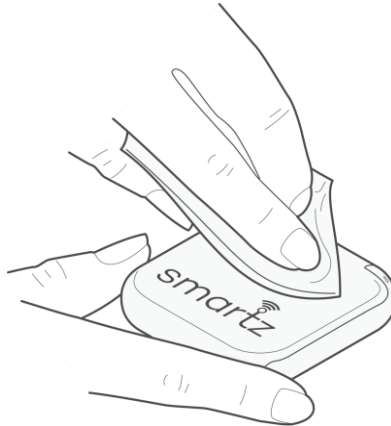

- *Allow the Smartz pod to thoroughly air dry, especially around the gold pins before commencing usage. Be careful of the sharp edges of these pins.*
- *Store in a cool, dry place free of dust and lint, with the clip lid closed, until next use.*



3.9 Disposal

This section describes the steps to safely dispose of the Smartz® components and accessories.

Smartz® sensor Pad/brief

The Smartz® sensor Pad/brief may pose a biohazard risk after usage. The Smartz® sensor Pad/brief should be disposed of appropriately according to the Pad/brief manufacturer instructions.

Smartz® pod

The Smartz® pod contains electronic parts and CR2016 Lithium batteries. These should be disposed of in accordance with WEEE 2002/96/EC European Directive. This stipulates the proper disposal of electrical and electronic equipment. These devices should be disposed of separately, not as unsorted municipal waste. To dispose of the device, use appropriate collection, reuse and recycling systems available in your region. The use of these collection, reuse and recycling systems is designed to reduce pressure on natural resources and prevent hazardous substances from damaging the environment. For more information on these disposal systems, please contact your local waste administration. The crossed-bin symbol invites you to use these disposal systems. If further information is required for the collection and disposal of Smartz Operations Pty Ltd devices, please contact Smartz Operations Pty Ltd.

The Smartz® pod has a design life of three (3) years. Standards and Compliance and IEC Certifications.

The Smartz® pod was developed in accordance with pertinent North American and international standards.

Description	Specification
Model Number	9000
Mode of operation	Continuous Operation
Protection against dust and water	IP 54
Applied Part	Type BF
Use in presence of flammable aesthetic mixtures	No
Suitable for sterilization	No

General & Collateral Standards - Smartz® Pod

- Medical electrical equipment - Part1: General requirements for basic safety and essential performance IEC /EN 60601-1 (2005/2006 +C1+C2)
- Medical electrical equipment - Part1: General requirements for safety –collateral standard electromagnetic compatibility requirements performance IEC 60601-1-2:2015
- Medical Electrical Equipment-Part 1-11: General requirements for basic safety and essential performance – Collateral standard: Requirements for medical electrical equipment and medical electrical systems used in the home healthcare environment, IEC 60601-1-11:2015

SECTION 4

TROUBLESHOOTING , CONTACT AND SUPPORT

4.0 Troubleshooting, Contact and Support

4.1 Troubleshooting

View Troubleshooting: <https://smartzhealth.com/FAQs>

4.2 Contact and support

Please contact Smartz Operations Pty Ltd or your authorized distributor via the contact information provided for assistance, if required, in setting up, using, maintaining or purchasing the Smartz® system or to report unexpected operations or events.

If a serious incident as occurred in relation to using this device, this should be reported to the manufacturer below and to the relevant competent authority of the Member State in which the user or patient is established.

Customer Service Contact: Australia and New Zealand

Inside Australia Phone: +61 2 84 05 63 00

Outside Australia Phone: +41 41 562 04 96

Email: customerservice@smartzag.com

Note: Authorized distributors can be found at the website below:

Website: www.smartzag.com

Appendix A

Smartz®

SPECIFICATIONS

5.0 Appendix A Smartz® System Specifications

Smartz® Physical Specifications

Description	Length (mm)	Width (mm)	Height (mm)	Weight (g)
Smartz® pod (inc. battery)	40	38	9	16

Smartz® Electrical Specifications

Smartz® pod Replaceable Battery

Description	Specification
Brand	Panasonic CR2016
Chemistry	Lithium
Voltage	3.0 Vdc
Ampere Hour Rating	90 mAh

The battery typically has a life of 3 months

Smartz® pod Bluetooth Specifications

The wireless specifications are as follows;

Description	Specification
BLE	Version 4/5
Frequency Band	2.400 – 2.485 GHz

Smartz® service Life

The service life of a Smartz pod is 3 years.

[Smartz® pod can be connected consistently and successfully to the absorbent article for 4380 times after clipping and unclipping]

WARNING

The Smartz® pod may be interfered with by other equipment, even if that other equipment complies with CISPR EMISSION requirements.

Smartz® Software Specifications

[Smartz® mobile app](#)

Notifications App

Description	Specification
Name	Smartz® Notification
Operating System	Android 6 or greater, iOS 13 or greater
Version of app	Refer to app interface

[Smartz® dashboard specifications](#)

Description	Specification
Dashboard URL	dashboard.smartzhealth.com
Browser	Google Chrome, Microsoft Edge and Safari
Version of dashboard	Refer to dashboard

Smartz® System Transport and Environmental Specifications

System components shall be capable of transportation and storage outside of its protective packaging at the following environmental limits;

- -25°C to +5°C without relative humidity control
- +5°C to + 35°C at a relative humidity up to 90%, non-condensing
- >35°C to +70°C at a water vapour pressure up to 50hPa

When connected to a sensor, the pod shall operate across the entire range of the following environmental conditions;

- a temperature range of + 5°C to + 40°C;
- a relative humidity range of 15 % to 90%, non-condensing but not requiring a vapour partial pressure >50hPa; and
- an atmospheric pressure range of 700 kPa to 1,060 kPa.

The user must take precaution to ensure they use the device within these conditions during foreseeable use. If the environmental conditions are outside these limits, the user shall not use the device.

Smartz® System Patient Environment

The Smartz® system is Radio Equipment Device certified for use in a medical environment. Smartz Operations Pty Ltd has tested, certified and classified the Smartz® pod as a Radio Equipment Device.

⚠ WARNING

1. In order to ensure that patient safety is maintained at all times, the Smartz® pod or other electrical equipment must not be placed within the patient environment as defined and illustrated below.
2. In case of emergency, disconnect the equipment from power supply mains.
3. In order to ensure that patient safety is maintained at all times, the operator must not touch the Patient at the same time if the patient is connected to the Smartz® pod and the sensor Pad/brief

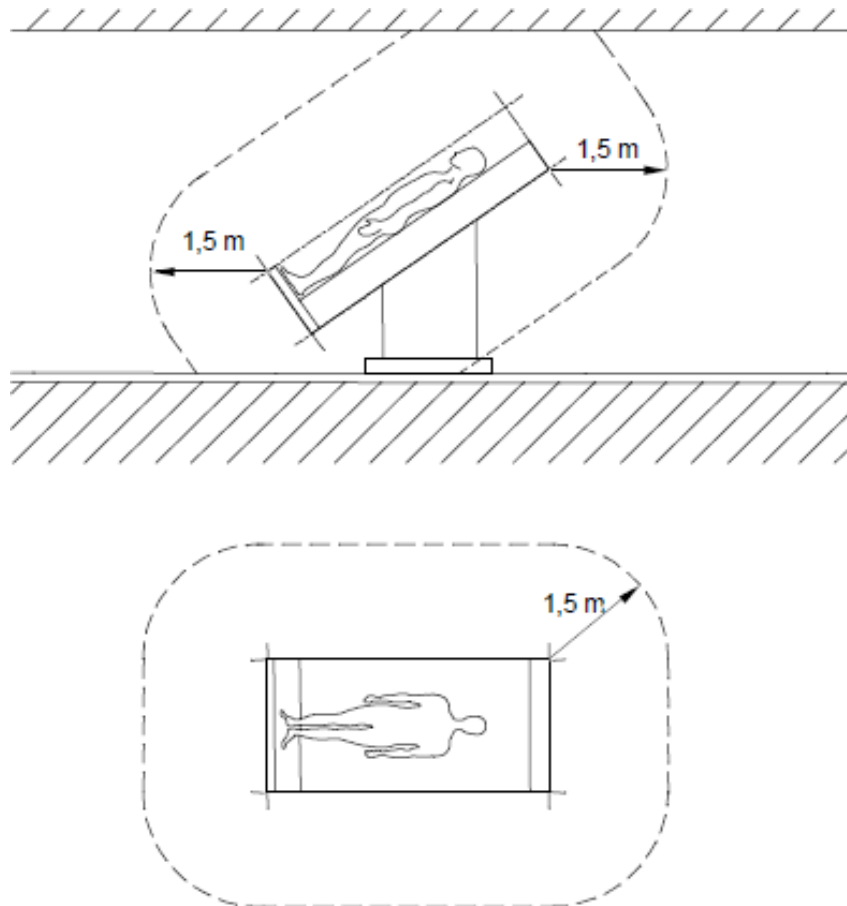

WARNING

Portable and mobile RF communications equipment can affect the performance of the Smartz® system. Install and use the system according to the information contained in this manual.

IEC 2431/05

FCC COMPLIANT STATEMENT

Changes or modifications not expressly approved by Smartz AG could void the user's authority to operate the equipment.

This device complies with Part 15 of FCC Rules. Operation is subject to the following two conditions: (1) this device may not cause harmful interference, and (2) this device must accept any interference received, including interference that may cause undesired operation

Note: This equipment has been tested and found to comply with the limits for a Class B digital device, pursuant to part 15 of the FCC Rules. These limits are designed to provide reasonable protection against

harmful interference in a residential installation. This equipment generates, uses and can radiate radio frequency energy and, if not installed and used in accordance with the instructions, may cause harmful interference to radio communications. However, there is no guarantee that interference will not occur in a particular installation. If this equipment does cause harmful interference to radio or television reception, which can be determined by turning the equipment off and on, the user is encouraged to try to correct the interference by one or more of the following measures:

- Reorient or relocate the receiving antenna.
- Increase the separation between the equipment and receiver.
- Connect the equipment into an outlet on a circuit different from that to which the receiver is connected.
- Consult the dealer or an experienced radio/TV technician for help.

DEVICES COVERED UNDER RSS

This device contains licence-exempt transmitter(s)/receiver(s) that comply with Innovation, Science and Economic Development Canada's licence-exempt RSS(s). Operation is subject to the following two conditions: 1. This device may not cause interference. 2. This device must accept any interference, including interference that may cause undesired operation of the device.

L'émetteur/récepteur exempt de licence contenu dans le présent appareil est conforme aux CNR d'Innovation, Sciences et Développement économique Canada applicables aux appareils radio exempts de licence. L'exploitation est autorisée aux deux conditions suivantes : 1. L'appareil ne doit pas produire de brouillage; 2. L'appareil doit accepter tout brouillage radioélectrique subi, même si le brouillage est susceptible d'en compromettre le fonctionnement.

The Smartz® pod Model 9000 requires special precautions regarding EMC and needs to be installed and put into service according to the EMC information provided in these accompanying documents.

➤ WARNINGS

Portable RF communications equipment (including peripherals such as antenna cables and external antennas) should be used no closer than 30 cm (12 inches) to any part of the Smartz® pod Model 9000, including cables specified by the manufacturer. Otherwise, degradation of the performance of this equipment could result.

A risk of increased emissions or decreased immunity may result if any additional cables are attached.

Use of this equipment adjacent to or stacked with other equipment should be avoided because it could result in improper operation. If such use is necessary, this equipment and the other equipment should be observed to verify that they are operating normally.

Use of accessories, transducers and cables other than those specified or provided by the manufacturer of this equipment could result in increased electromagnetic emissions or decreased electromagnetic immunity of this equipment and result in improper operation.

1	Guidance and Manufacturer's Declaration – electromagnetic emissions		
2	The Smartz® pod Model 9000 is intended for use in the electromagnetic environment specified below. The customer or the user of the Smartz® pod Model 9000 should assure that it is used in such an environment.		
3	Emission Test	Compliance	Electromagnetic environment –guidance
4	RF emission CISPR 11	Group 1	The Smartz® pod Model 9000 uses RF energy only for its internal function. Therefore, its RF emissions are very low and are not likely to cause any interference in nearby electronic equipment.
5	RF emissions CISPR 11	Class B	The Smartz® pod Model 9000 is suitable for use in all establishments, including domestic establishments and those directly connected to the public low-voltage power supply network that supplies buildings used for domestic purpose.

Guidance and Manufacturer's Declaration – electromagnetic immunity			
The Smartz® pod Model 9000 is intended for use in the electromagnetic environment specified below. The customer or the user of the Smartz® pod Model 9000 should assure that it is used in such an environment.			
Immunity Test	IEC 60601-1 Test level	Compliance Test	Electromagnetic environment - guidance
Electrostatic Discharge (ESD) IEC 61000-4-2	+ 8kV contact + 15kV air	+ 8kV contact + 15kV air	Floors should be wood, concrete or ceramic tile. If floors are covered with synthetic material, the relative humidity should be at least 30%.
Power frequency (50/60 Hz) magnetic field IEC 61000-4-8	30 A/m	30 A/m	Power frequency magnetic fields should be at levels characteristic of a typical location in a typical commercial or hospital environment.
Radiated RF IEC 61000-4-3	10 V/m 80 MHz to 2.7 GHz	10 V/m 80 MHz to 2.7 GHz	Portable and mobile RF communications equipment should be used no closer to any part of the Smartz® pod Model 9000, including cables, than the recommended separation distance calculated from the equation applicable to the frequency of the transmitter. Recommended separation distance $d = [3.5/10] \sqrt{P}$ 80 MHz to 800 MHz $d = [7/10] \sqrt{P}$ 800 MHz to 2.7 GHz where P is the maximum output power rating of the transmitter in watts (W) according to the transmitter manufacturer and d is the recommended separation distance in meters (m). Field strengths from fixed RF transmitters, as determined by an electromagnetic site survey,

			<p>should be less than the compliance level in each frequency range. Interference may occur in the vicinity of equipment marked with the following symbol:</p> 
--	--	--	---

--	--	--	--

Note 1: At 80 MHz and 800 MHz, the higher frequency range applies.
Note 2: These guidelines may not apply in all situations. Electromagnetic propagation is affected by absorption and reflection from structures, objects and people.

Field strengths from fixed transmitters, such as base stations for radio (cellular/cordless) telephones and land mobile radios, amateur radio, AM and FM radio broadcast and TV broadcast cannot be predicted theoretically with accuracy. To assess the electromagnetic environment due to fixed RF transmitters, an electromagnetic site survey should be considered. If the measured field strength in the location in which the Smartz® pod Model 9000 is used exceeds the applicable RF compliance level above, the Smartz® pod Model 9000 should be observed to verify normal operation. If abnormal performance is observed, additional measures may be necessary, such as re-orienting or relocating the Smartz® pod Model 9000.

Guidance and Manufacturer’s Declaration – electromagnetic immunity

The Smartz® pod Model 9000 is intended for use in the electromagnetic environment specified below. The customer or the user of the Smartz® pod Model 9000 should assure that it is used in such an environment.

Immunity Test	IEC 60601-1 Test level	Compliance Test	Electromagnetic environment - guidance
IMMUNITY to proximity fields from RF wireless communications equipment	MHz – Modulation – Field Strength 385 - 18 Hz - 27 V/m	MHz – Modulation – Field Strength 385 - 18 Hz - 27 V/m 450 - 18 Hz - 28 V/m	Portable and mobile RF communications equipment should be used no closer to any part of the Smartz® pod Model 9000, including cables, than the recommended separation distance calculated

	450 - 18 Hz - 28 V/m 710 - 217 Hz - 9 V/m 745 - 217 Hz - 9 V/m 780 - 217 Hz - 9 V/m 810 - 18 Hz - 28 V/m 870 - 18 Hz - 28 V/m 930 - 18 Hz - 28 V/m 1720 - 217 Hz - 28 V/m 1845 - 217 Hz - 28 V/m 1970 - 217 Hz - 28 V/m 2450 - 217 Hz - 28 V/m	710 - 217 Hz - 9 V/m 745 - 217 Hz - 9 V/m 780 - 217 Hz - 9 V/m 810 - 18 Hz - 28 V/m 870 - 18 Hz - 28 V/m 930 - 18 Hz - 28 V/m 1720 - 217 Hz - 28 V/m 1845 - 217 Hz - 28 V/m 1970 - 217 Hz - 28 V/m 2450 - 217 Hz - 28 V/m	from the equation applicable to the frequency of the transmitter. Recommended separation distance $E = [6/d] \text{ vP}$ $d = [6/E] \text{ vP}$ where P is the maximum output power rating of the transmitter in watts (W) according to the transmitter manufacturer, d is the recommended separation distance in meters (m), and E is the field strength in V/m. Field strengths from fixed RF transmitters, as determined by an electromagnetic site survey, should be less than the compliance level in each frequency range. Interference may occur in
	5240 - 217 Hz - 9 V/m 5500 - 217 Hz - 9 V/m 5785 - 217 Hz - 9 V/m	5240 - 217 Hz - 9 V/m 5500 - 217 Hz - 9 V/m 5785 - 217 Hz - 9 V/m	the vicinity of equipment marked with the following symbol: 
Note: These guidelines may not apply in all situations. Electromagnetic propagation is affected by absorption and reflection from structures, objects and people.			

Recommended distances between portable and mobile RF communications equipment as well as RF wireless communications equipment the Smartz® pod Model 9000				
The Smartz® pod Model 9000 is intended for use in an electromagnetic environment in which radiated RF disturbances are controlled. The customer or the user of the Smartz® pod Model 9000 can help prevent electromagnetic interference by maintaining a minimum distance between portable and mobile RF communications equipment (transmitters) and the Smartz® pod Model 9000 as recommended below, according to the maximum output power of the communications equipment.				
Rated maximum output power of transmitter (W)	Separation distance according to frequency of transmitter (m)			
	80 to 800 MHz $d = [3.5/10] \text{ vP}$	800 MHz to 2.7 GHz $d = [7/10] \text{ vP}$	710, 745, 780, 5240, 5500, 5785 $d = [6/9] \text{ vP}$	385, 450, 810, 870, 930, 1720, 1845, 1970, 2450 $d = [6/28] \text{ vP}$
0.01	0.035	0.070	0.067	0.021
0.1	0.110	0.221	0.211	0.070

1	0.350	0.700	0.667	0.214
10	1.107	2.213	2.108	0.700
100	3.500	7.000	6.670	2.143

For transmitters rated at a maximum output power not listed above, the recommended separation distance (d) in meters (m) can be estimated using the equation applicable to the frequency of the transmitter, where P is the maximum output power rating of the transmitter in watts (W) according to the transmitter manufacturer.

Note 1: At 80 MHz and 800 MHz, the separation distance for the higher frequency range applies.

Note 2: These guidelines may not apply in all situations. Electromagnetic propagation is affected by absorption and reflection from structures, objects and people.

Appendix B

Smartz® Accessories

6.0 Appendix B: Accessories

[Smartz® node and Mesh Network Overview](#)

The Smartz® node is a networking device designed to receive short-range Bluetooth data from Smartz® pods and relay the data via Wi-Fi to the Smartz® cloud. Multiple Smartz® nodes can form a 'mesh' network to enhance signal coverage for Patient monitoring. Smartz® nodes should be strategically placed around the facility in order to extend the range, taking into account confined spaces around walls and open space areas. There is at least one 'Master Node' that directly connects to the internet and this parent node collects data from all the other child nodes in the facility as a local network.

[Smartz® node and mesh network design and setup](#)

The Smartz® node and mesh network must be designed and set up by a trained technician. Refer to the following documentation, available from Smartz®:

- WI 02944 Node Planning and Deployment
- WI 02935 Node Setup Guide

[Smartz® node specifications](#)

The Smartz® node is an off-the-shelf hardware, customised firmware accessory.

Description	Specification
Smartz Operations Pty Ltd. Product Name	Smartz® node
Node Model No.	9100

SECTION 7
Glossary

7.0 Glossary

CE:

Conformité Européenne

FCC:

Federal Communications Commission

ID:

Identification

IEC:

International Electrotechnical Commission

ISO:

International Organization for Standardization

IT:

Information Technology

MAC Address:

Media Access Control Address

RCM:

Regulatory Compliance Mark

RF:

Radio Frequency

SAS:

Smart Alert System

URL:

Uniform Resource Locator

WEEE:

Waste Electrical and Electronic Equipment

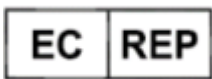

MedNet EC-REP GmbH
Borkstrasse 10,
48163 Munster, Germany



MADE IN AUSTRALIA by Smartz Operations Pty Ltd, Suite 2.02, Level 2, 54 Miller St, North Sydney, NSW 2060, Australia.

See www.smarzag.com for more information.